

VERSION	AMENDMENT	AUTHORISED BY	DATE

HELD BY LANDGATE IN DIGITAL FORMAT ONLY

TYPE FREEHOLD S.S.A. YES

PURPOSE SUBDIVISION

PLAN OF LOTS 1900, 2000-2010, 2022, 2023, 9042, 9043, ROADS, EASEMENTS AND RESTRICTIVE COVENANT

FORMER TENURE SEE FORMER TENURE TABLE

LOCAL AUTHORITY CITY OF SWAN

LOCALITY CAVERSHAM

D.O.L. FILE

FIELD RECORD 133837, 128056, 115997

SURVEYOR'S CERTIFICATE - REG 54
 I, Nigel J. SIMPSON
 hereby certify that this plan is accurate and is a correct representation of the -
 (a) *survey, and/or
 (b) *calculations from measurements recorded in the field records,
 [* delete if inapplicable]
 undertaken for the purposes of this plan and that it complies with the relevant written law(s) in relation to which it is lodged.

FINAL
 LICENSED SURVEYOR DATE

LOGGED

DATE FEE PAID ASSESS No.

I.S.C. EXAMINED DATE

WESTERN AUSTRALIAN PLANNING COMMISSION
 FILE 154751, 150929
 Delegated under S. 16 P&D Act 2005 DATE

IN ORDER FOR DEALINGS
 SUBJECT TO

FOR INSPECTOR OF PLANS AND SURVEYS DATE
 APPROVED REG26A (4)

INSPECTOR OF PLANS AND SURVEYS DATE
 (S. 18 Licensed Surveyors Act 1909)



DEPOSITED PLAN
4 13425
 SHEET 01 OF 03 SHEETS
 (PLUS SURVEY SHEETS(S))
 VERSION 1

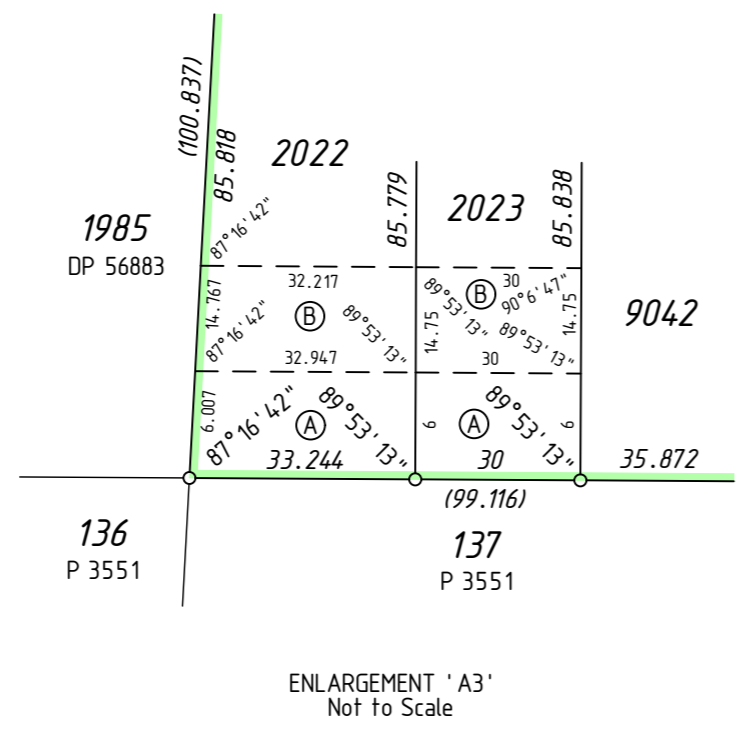
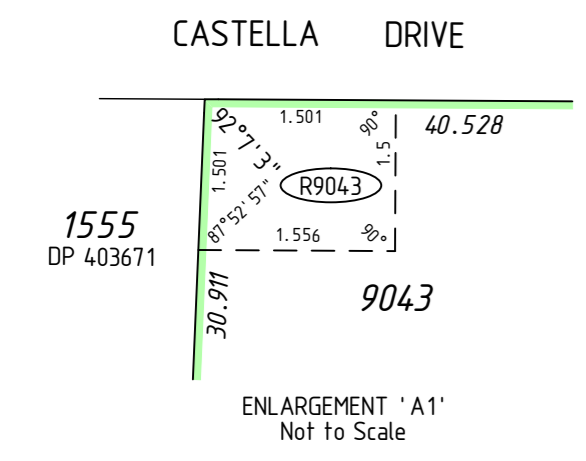
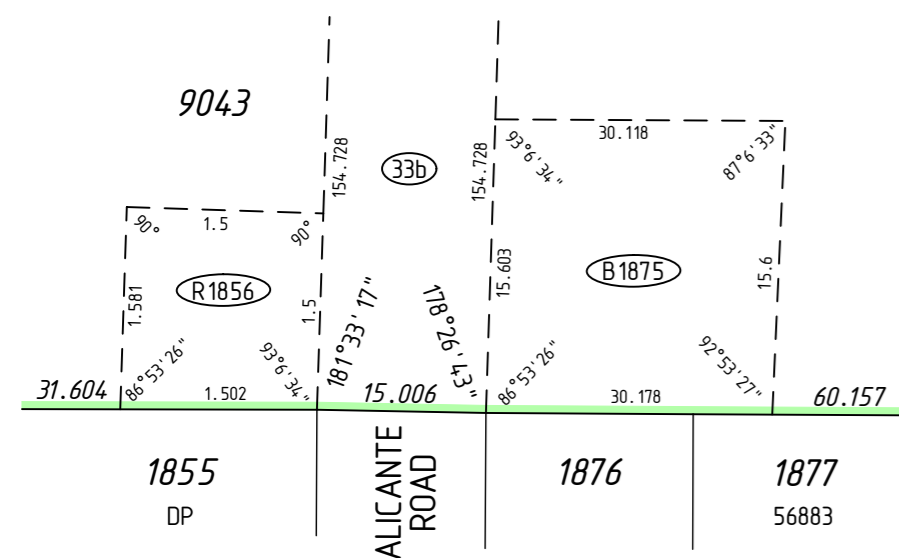
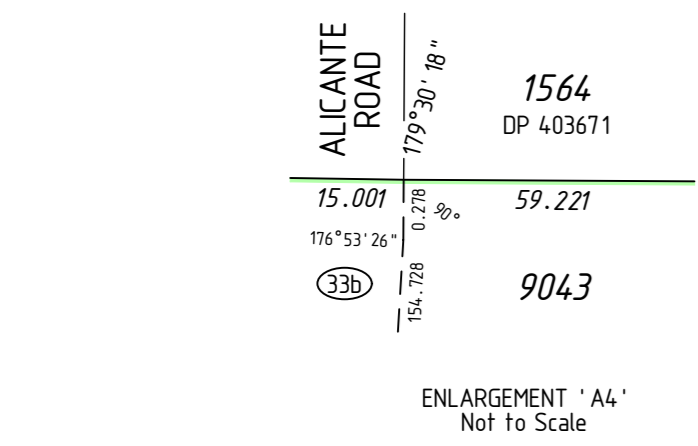
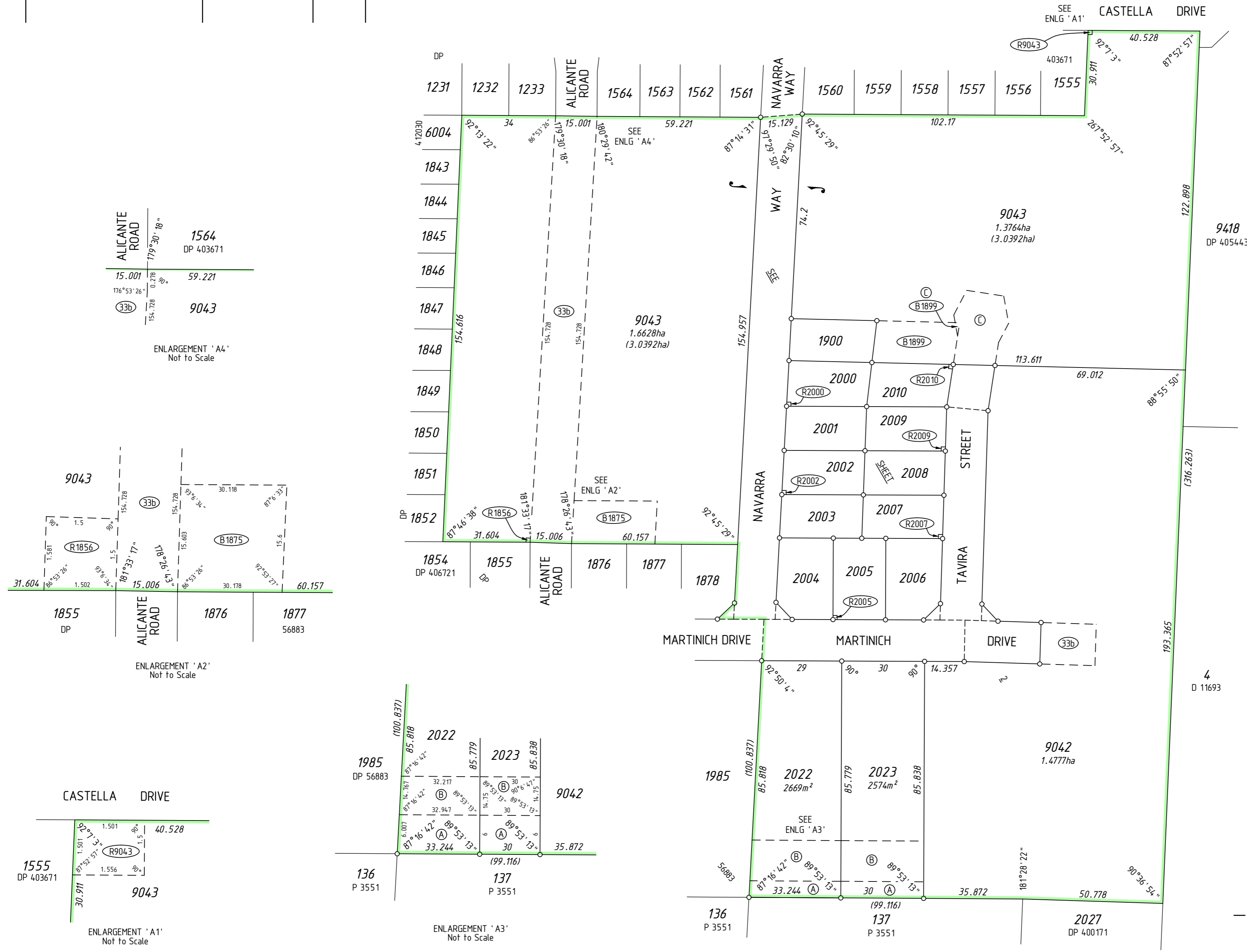

FORMER TENURE TABLE

LOT	FORMER TENURE	ON PLAN / DIAGRAM	TITLE
2000-2010, 2022, 2023 & 9042	Pt LOT 9436	DP 400171	2934-313
1900 & 9043	Pt LOT 9437	DP 56883	2934-877
ROAD	LOT 9438	DP 56883	2934-878

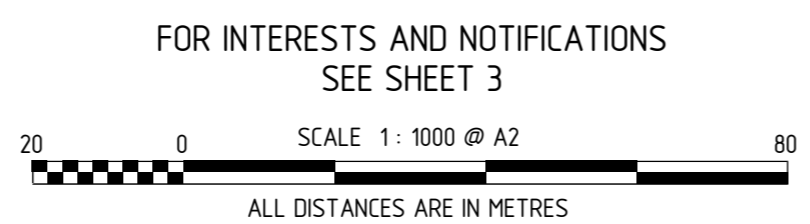

SURVEY CARRIED OUT UNDER REG 26A
 SPECIAL SURVEY AREA GUIDELINES
 SEE SURVEY SHEETS FOR SURVEY INFORMATION
 USE ONLY THE SURVEY SHEET/S WHEN DETERMINING
 THE TRUE FINAL POSITION AND TYPE OF ALL SURVEY
 MARKS PLACED PERTAINING TO THIS PLAN.

MC MULLEN NOLAN GROUP
 PO Box 3526, Success W.A. 6964
 Tel: (08) 6436 1599
 Fax: (08) 6436 1500
 Email: info@mngsurvey.com.au
 MNG Ref : 95324dp-281d - Stage 16A - DP413425.CSD

SEE SHEET 1

FOR HEADING SEE SHEET 1

FOR INTERESTS AND NOTIFICATIONS
SEE SHEET 3

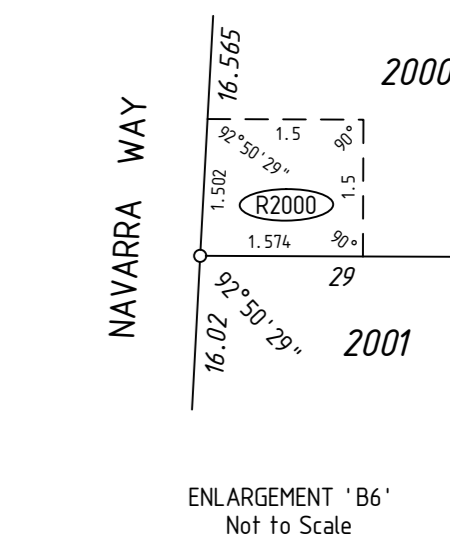
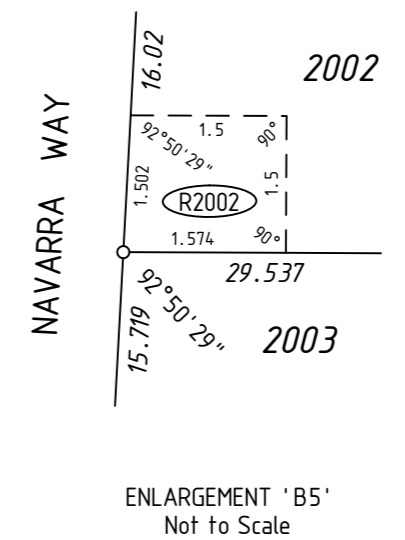
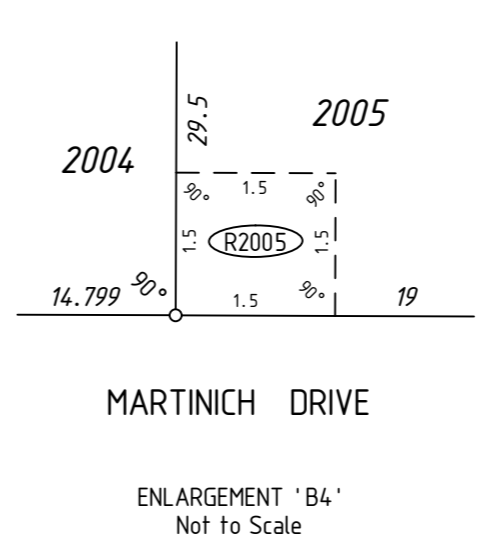
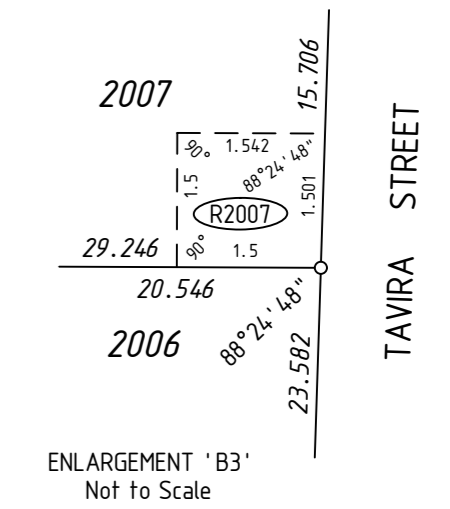
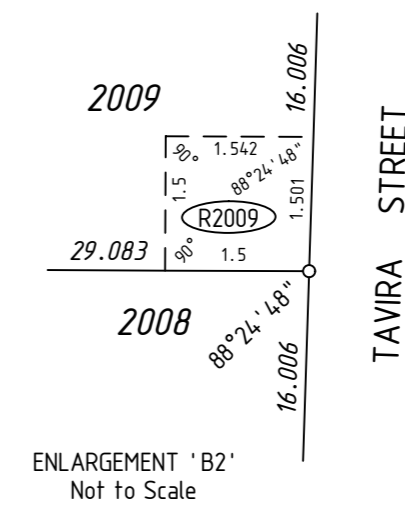
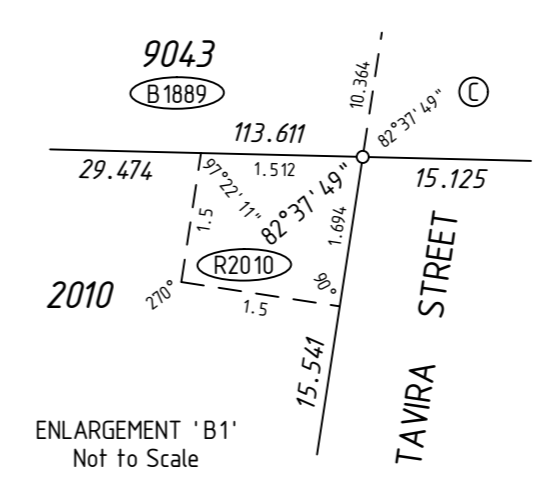
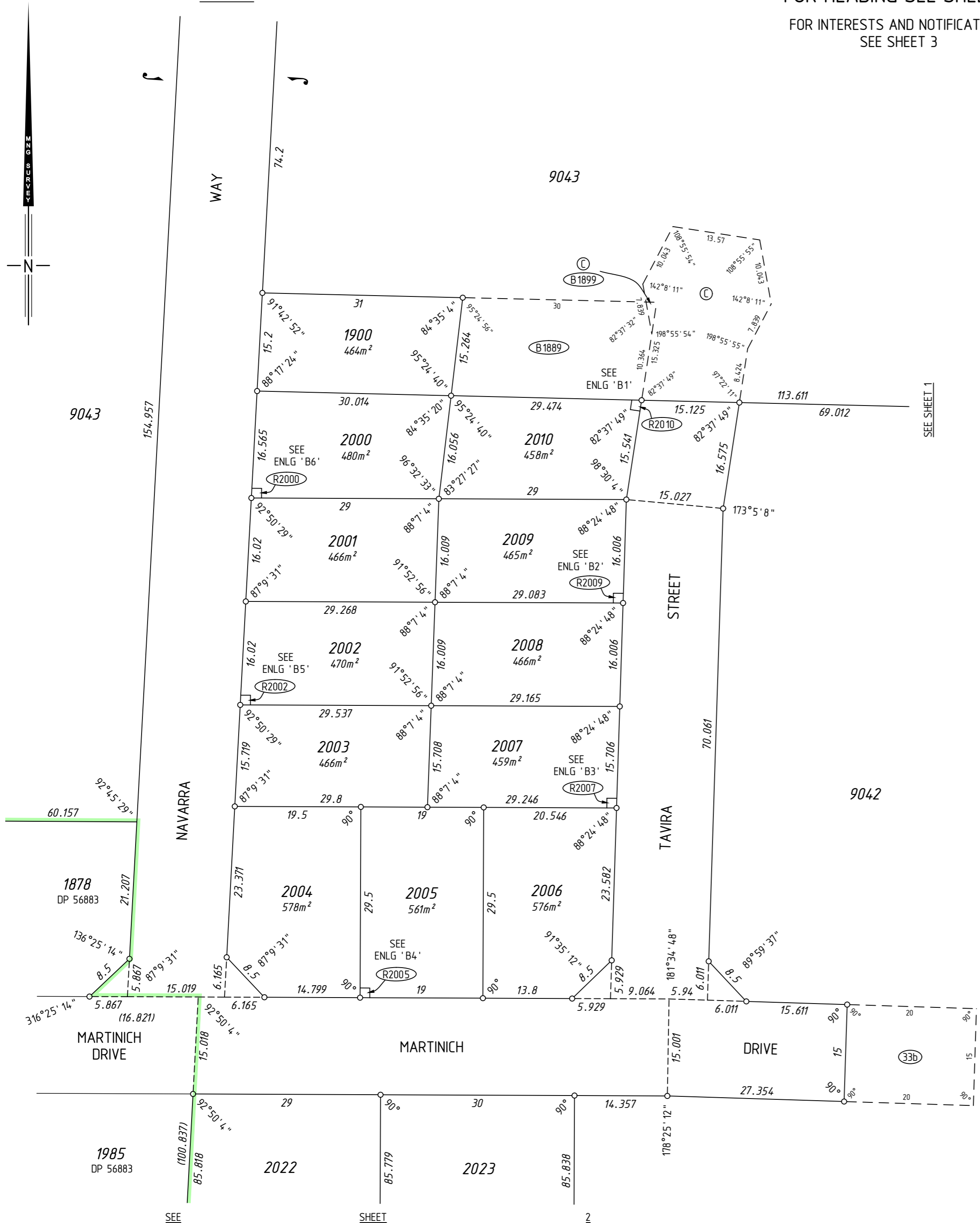

SURVEY CARRIED OUT UNDER REG 26A
SPECIAL SURVEY AREA GUIDELINES
SEE SURVEY SHEETS FOR SURVEY INFORMATION

USE ONLY THE SURVEY SHEET/S WHEN DETERMINING
THE TRUE FINAL POSITION AND TYPE OF ALL SURVEY
MARKS PLACED PERTAINING TO THIS PLAN.

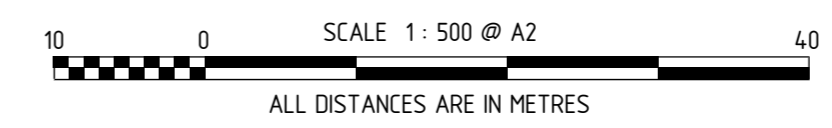



MNG Ref : 95324dp-281d - Stage 16A - DP413425.CSD

FINAL

LICENSED SURVEYOR

DATE



GOVERNMENT OF
WESTERN AUSTRALIA



Landgate

DEPOSITED PLAN

4 13425

SHEET 02 OF 03 SHEETS
VERSION 1

INTERESTS AND NOTIFICATIONS

SUBJECT	PURPOSE	STATUTORY REFERENCE	ORIGIN	LAND BURDENED	BENEFIT TO	COMMENTS
R9043	EASEMENT (Drainage)	SEC 136C OF THE T.L.A.	DP 403671	LOT 9043	LOT 1555 ON DP 403671	
B1875	EASEMENT (Drainage)	SEC 136C OF THE T.L.A.	DP 56883	LOT 1876 ON DP 56883	LOT 9043	
R1856	EASEMENT (Drainage)	SEC 136C OF THE T.L.A.	DP 56883	LOT 9043	LOT 1855 ON DP 56883	
33b	EASEMENT (Sewerage)	SEC 167 OF THE P. & D. ACT REG 33 (b)	THIS PLAN	LOTS 9042 & 9043	WATER CORPORATION	
33b	EASEMENT (Water Supply)	SEC 167 OF THE P. & D. ACT REG 33 (b)	THIS PLAN	LOT 9043	WATER CORPORATION	
R2000	EASEMENT (Drainage)	SEC 136C OF THE T.L.A.	THIS PLAN	LOT 2000	LOT 2001	
R2002	EASEMENT (Drainage)	SEC 136C OF THE T.L.A.	THIS PLAN	LOT 2002	LOT 2003	
R2005	EASEMENT (Drainage)	SEC 136C OF THE T.L.A.	THIS PLAN	LOT 2005	LOT 2004	
R2007	EASEMENT (Drainage)	SEC 136C OF THE T.L.A.	THIS PLAN	LOT 2007	LOT 2006	
R2009	EASEMENT (Drainage)	SEC 136C OF THE T.L.A.	THIS PLAN	LOT 2009	LOT 2008	
R2010	EASEMENT (Drainage)	SEC 136C OF THE T.L.A.	THIS PLAN	LOT 2010	LOT 9043 B1899	
	RESTRICTIVE COVENANT	SEC 136D OF THE T.L.A.	THIS PLAN & DOC	ALL LOTS EXCEPT 9042 & 9043	ALL LOTS EXCEPT 9042 & 9043	
B	RESTRICTIVE COVENANT	SEC 129BA OF THE T.L.A.	DOC	LOTS 2022 & 2023	CITY OF SWAN	
A	EASEMENT	SEC 195 OF THE L.A.A.	DOC	LOTS 2022 & 2023	CITY OF SWAN	ACCESS
C	EASEMENT	SEC 195 & 196 OF THE L.A.A.	DOC	LOT 9043	CITY OF SWAN AND THE PUBLIC AT LARGE	PUBLIC ACCESS
	NOTIFICATION	SEC 165 OF THE P. & D. ACT	DOC	ALL LOTS EXCEPT 9042 & 9043		PROXIMITY TO RURAL ZONED LAND
	NOTIFICATION	SEC 165 OF THE P. & D. ACT	DOC	ALL LOTS EXCEPT 9042 & 9043		PROXIMITY TO BRICKWORK OPERATION



MNG Ref : 95324dp-281d - Stage 16A - DP4 13425.CSD

FINAL

LICENSED SURVEYOR

DATE



DEPOSITED PLAN

4 13425

SHEET 03 OF 03 SHEETS
VERSION 1

FOR HEADING SEE SHEET 1

THIS SURVEY SHEET WILL BE
REPLACED BY THE SURVEY DATA



MNG Ref: 95324dp-281d



GOVERNMENT OF
WESTERN AUSTRALIA



DEPOSITED PLAN

4 13425

SURVEY SHEET